

MADE IN ITALY



LOGIC

INCLINED PLATFORM LIFT FOR STRAIGHT STAIRS

extrōma[®]
solutions in motion



Since Logic runs on **rechargeable batteries**, the lift can be used even in the event of power blackouts. The motor-operated platform and safety bars (provided as standard) simply enable the **fully automatic opening and closing** of the platform. Logic is designed for both indoor and outdoor installation and, thanks to the modular concept of the rail, it is **available for delivery in a few days**.



Logic has a **very reduced encumbrance** in the folded position.



Remote controls to call the stairlift from the floor or send it to the parking position.



Foldable seat for users not on wheelchair.



Wander lead for attendant control, with spiral cable.



1. The **touch button panel** allows to move ergonomically the lift from board by simply touching with your fingers or palm the luminous arrows for ascend/descent, with no need to press on them.
2. The **overload led** and the flashing light with sound alarm fulfill compliance to the existing Safety Regulations both in private and public places.
3. The **innovative electronic system** allows to keep constant track of the state of functioning, it considerably **simplifies diagnostics** and allows the installer to customize the main parameters according to the user's needs at any time.

TECHNICAL FEATURES OF LOGIC PLATFORM LIFT

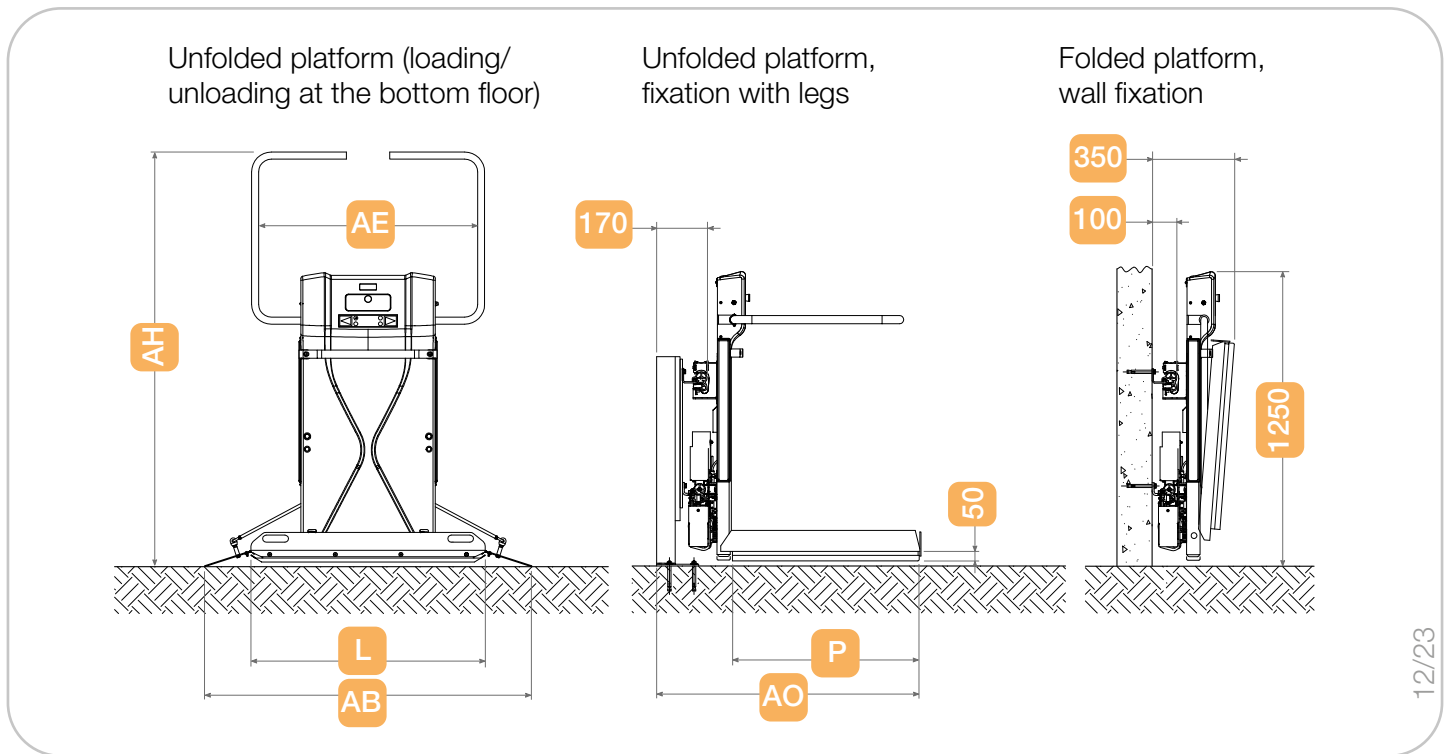

12/23

Platform dimensions (LxP)	750x600	750x650	750x700	850x700	1000x800	1250x800
AB Overall platform length	1165	1165	1165	1265	1400	1650
AE Overall useful length within barrier arms	745	745	745	825	975	1225
AH Overall height unfolded platform	1640	1690	1690	1690	1765	1765
AO Unfolded platform (wall fixation) (*)	850	900	950	950	1050	1050
AO Unfolded platform (fixation with legs) (*)	920	970	1020	1020	1120	1120

(*) In case of frontal access (optional), add 25 mm

Technical data	
Load capacity	250 Kg (300 optional)
Surmountable inclination	0°-45°
Speed	0,10 m/s
Control circuits voltage	24 V DC
Maximum power on board	0,54 kW
Main voltage	100-240V AC
Soft start and soft stop system	standard fitted
IP rating	IP 54

Colours	
Platform (**)	Dark Gray (similar to RAL 7011)
Fixings (**)	RAL 9006
Rails	Aluminium Silver anodized
(**) other RAL colours available on request	

Compliance
2006/42/CE (ref. standard EN 81-40:2020)

All dimensions are expressed in millimeters and all information contained in this catalogue have to be ment purely indicative. Extrema reserve the right to change at any time the information here reported without prior notification.

extrema[®]
solutions in motion

Extrema S.r.l.
Via dell'Industria 2
46031 Bagnolo San Vito (MN) - I
Tel. (+39) 0376 252443
Fax (+39) 0376 251091
extremalifts.eu



For further information see our website extremalifts.eu