

MADE IN ITALY



# SLIM X

INCLINED PLATFORM LIFT FOR CURVED STAIRS



Slim X is a Stairlift for standing or seated people. The special **rope traction system** presents major benefits in respect of the traditional rack-and-pinion system commonly offered on the market: can suit to **very narrow staircases** (min. passage required 820 mm), installation is possible both on the inner and outer side of the staircase as well as with very low headbulk. **Silent** when functioning and **comfortable for the user**.



Slim X is **designed to occupy the minimum space** on the staircase and in the parking zones.



**Remote controls** to call the stairlift from the floor or send it to the parking position.



**Foldable seat** for users not on wheelchair.



**Wander lead** for attendant control, with spiral cable.



1. The up and down **buttons** are placed in the center of the platform, the user can easily reach them.
2. The **emergency button** ensures the immediate stop of the platform and, if pressed, it highlights any accidental pressures.
3. The **key** can avoid the use of the stairlift by unauthorized people.
4. The **innovative electronic system** allows to keep constant track of the state of functioning, it considerably **simplifies**

**diagnostics** and allows the installer to **customize the main parameters** according to the user's needs at any time.

# TECHNICAL FEATURES OF SLIM X PLATFORM LIFT

Unfolded platform  
(loading/ unloading at the bottom floor)

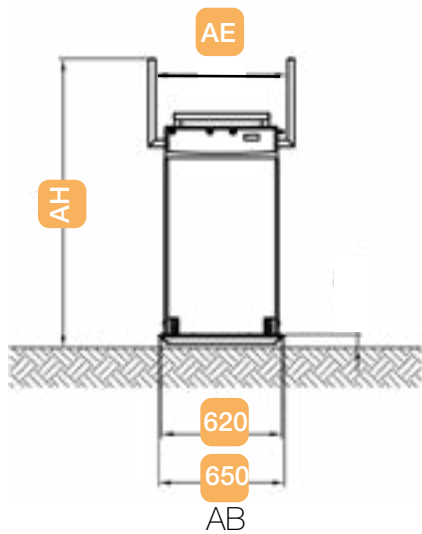

Unfolded platform,  
fixation with legs

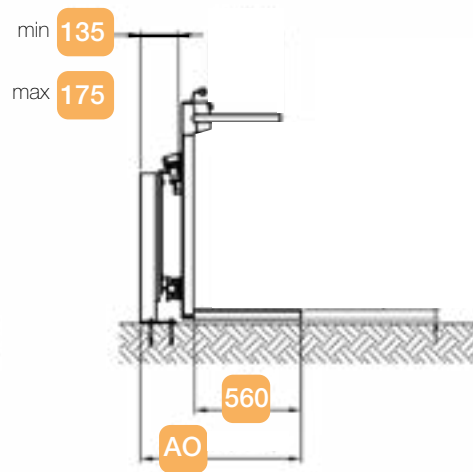

Folded platform,  
wall fixation

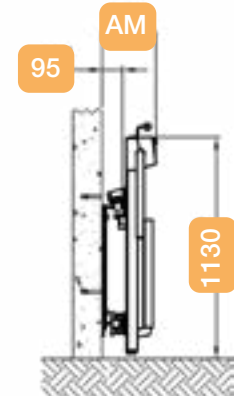

Platform dimensions (LxD)		620x545	Technical data	
<b>AB</b>	Overall platform length	650	Load capacity	150 Kg
<b>AE</b>	Overall useful length within barrier arms	675	Speed	0,10 m/s
<b>AH</b>	Overall height unfolded platform	1480	Main voltage	220 Vac 50 Hz
<b>AO</b>	Minimum stair width (wall fixation)	760	Control circuits voltage	24V DC
<b>AO</b>	Minimum stair width (fixation with legs)	840	Maximum power (up to 3 floors)	0,75 kW/1,5 KW
<b>AM</b>	Folded platform (wall fixation) (*)	265	Soft-start and soft-stop system	standard fitted
<b>AM</b>	Folded platform (fixation with legs) (*)	345	<b>Colours</b>	
Surmountable inclination			Platform (*)	
(In case of a gradient lower than 20° AM increases by 20 mm)			Standard RAL 7011	
			Rails, Fixings (*)	
			Standard RAL 9006	
			(*) other RAL colours available on request	

All dimensions are expressed in millimeters and all information contained in this catalogue have to be ment purely indicative. Extrema reserves the right to change at any time the information here reported without prior notification.

**extrema**<sup>®</sup>  
solutions in motion

Extrema S.r.l.  
Via dell'Industria 2  
46031 Bagnolo San Vito (MN) - I  
Tel. (+39) 0376 252443  
Fax (+39) 0376 251091  
extremalifts.eu

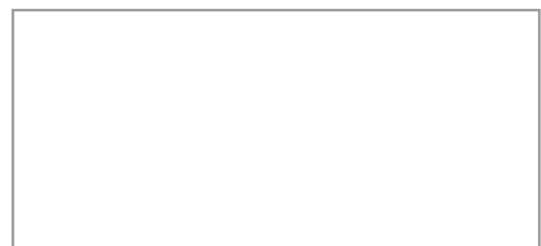

Rev.01 of 05/23